

Haitian Mars/G Series



# Haitian Mars/G Series Specifications

860-10000KN



**HAITIAN INTERNATIONAL HOLDINGS LIMITED**

Unit 1105 Level 11  
Metroplaza Tower 2  
223 Hing Fong RD Kwai Fong N.T  
haitian@mail.haitian.com  
www.haitian.com

**NINGBO HAITIAN HUAYUAN MACHINERY CO., LTD.**

Export Processing Zone, Ningbo 315800 China  
+86-574-86177242  
+86-574-86221864  
haitian@mail.haitian.com  
www.haitian.com

**Haitian Partner:**

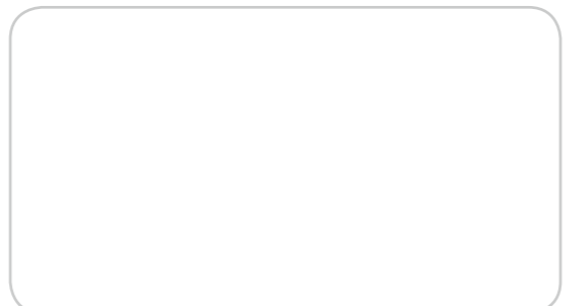

HT 20180321-IV

# Haitian Mars/G Series

## Servo drive energy-saving injection molding machine

Haitian is dedicated in providing customers with new technology to improve the production of their plastic parts. Our close cooperation with customers provide a better understanding for the challenges the injection molding industry has to face.

The Haitian Mars/G Series injection molding machine incorporates the latest energy saving technologies

With a robust design and a strong mechanical structure, the machine is optimized for durability and a long working life.

An intelligent user-friendly control system provides for an easy and reliable machine setup for precise molded parts.



- Aspiration for Excellence:** Continuous improvement with customer communication for optimized growth
- Quality Assurance:** Vertically integrated manufacturing with international quality practices
- Strong and Flexible:** Modular machine design with variable machine configurations
- Professional Service:** Prompt and efficient service support
- Safe Operation:** Global safety standards according to your region are strictly followed and compliant

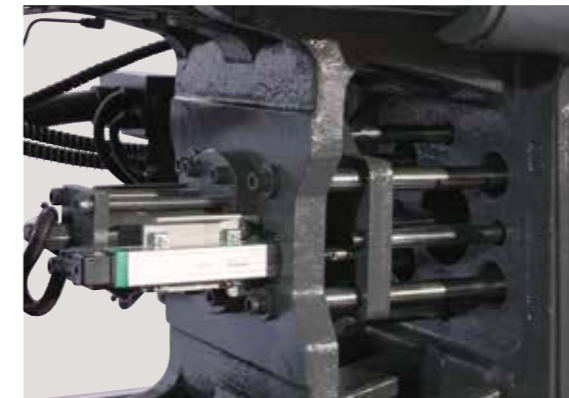

### Multi-point Ejection System

A great advantage for molds with different ejection requirements



### Various Plasticizing Screws

A wide range of screw designs is available according to your material processing requirements



### Automatic lubricating system

The clamping unit is optimized for precise lubrication of all moving parts



### High performance servo motor

Highly responsive with closed loop control for stability and precision



### Excellent injection performance

Twin-cylinder injection unit with strong guide system ensures durability and precision during the injection/charging stages of the molding cycle



# Haitian Mars/G Series

## Servo Drive energy-saving injection molding machine

### Patented Servo Hydraulic Drive System for Injection Molding Machines

Haitian is the global leader for servo hydraulic plastic injection molding machines.

The Mars Series machine was launched in 2007 and has become an industry bench mark with more than 120,000 machines sold.

Our patented servo motor/gear pump drive system was designed as a whole and is not a combination of standard market components as used by our competitors.

This translates into a significant advantage for repeatable high precision and low energy consumption for different molding applications and processing materials.



Servo motor with counter-rotation gear pumps

### Power consumption

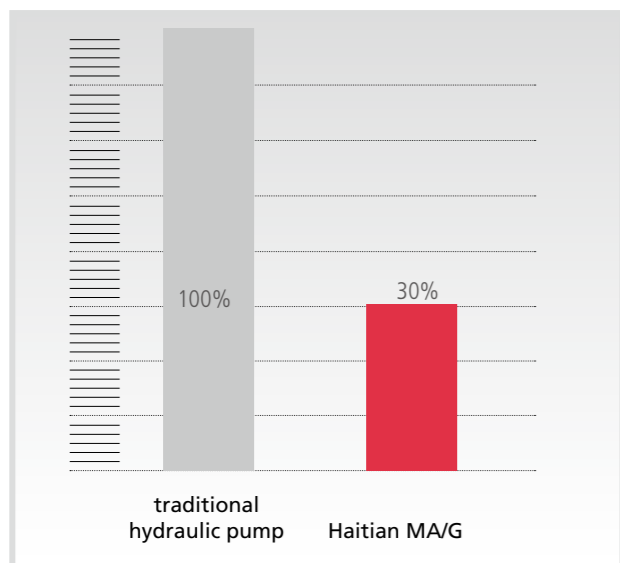

The Mars II drive system provides significant cost savings for machine energy consumption compared to traditional hydraulic drive systems.

### Water consumption

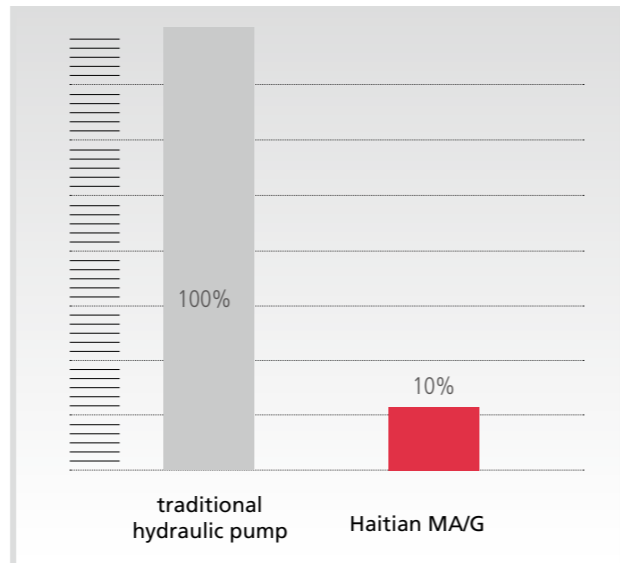

The consumption of hydraulic oil cooling water is dramatically reduced due to the on-demand control of the servo drive system. Only the required quantity of oil is used during each stage of the machine cycle, which eliminates bypass oil wastage as found in traditional hydraulic systems.

### Servo Hydraulic Drive System

The drive system utilizes a rotary encoder with pressure transducer for closed control for all machine movements. The precision and repeatability guarantees consistent molding parameters during the complete molding cycle. Fast speed and pressure changes provide a broad processing window for the molded part.

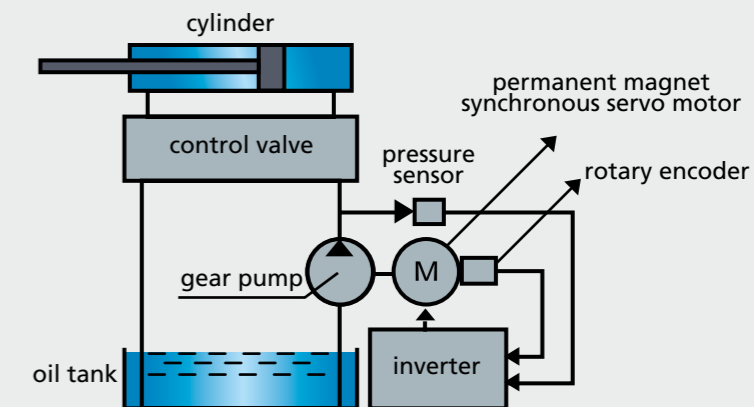

Quick response of drive system: 0.05s  
Energy saving rate: 30-80%

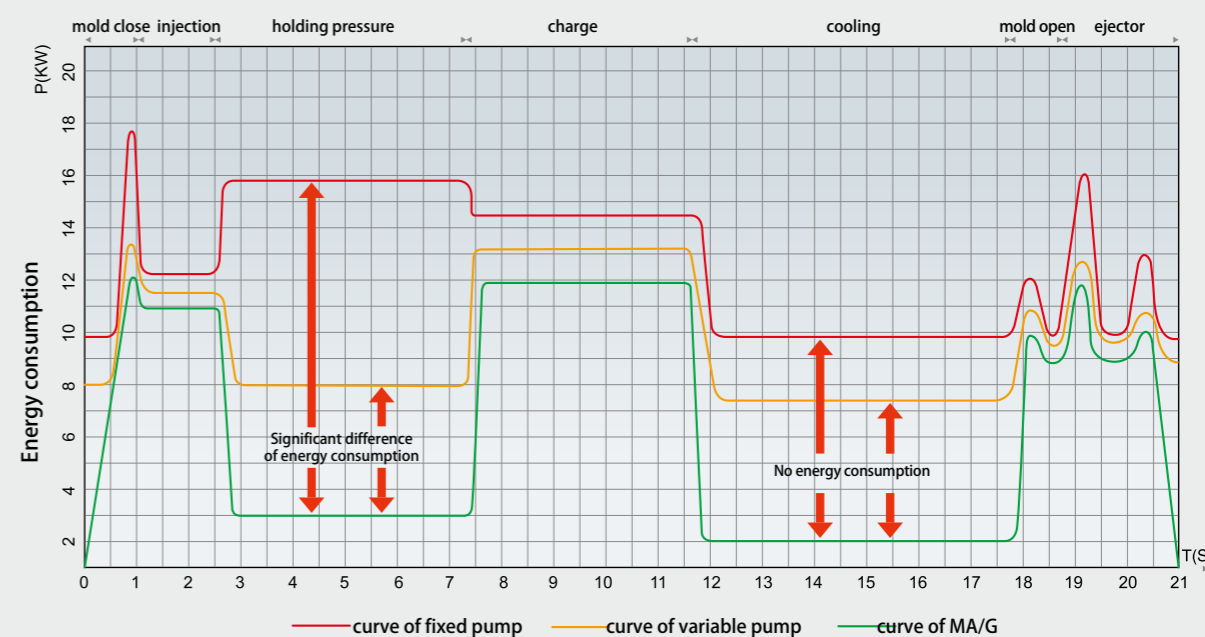

### Excellent energy-saving drive system

The drive system automatically adjusts the oil pressure and flow according to each stage of the molding cycle. The motor speed constantly changes to exactly meet the requirements to avoid any wastage, significantly reducing the energy consumption of the machine. During the cooling stage of the molding cycle, the motor stops, preventing undue energy consumption. This is a great advantage for thick-walled parts requiring long cooling times. Another significant advantage of the servo drive system is the energy consumption during the "holding stage" of the molding cycle. The motor reduces its speed to only deliver the oil flow needed to maintain the actually required pressure. Energy savings of 30% to 80% are achievable according to the respective parts.

# Specification

INJECTION UNIT	
Screw Diameter	mm
Screw L/D Ratio	L/D
Shot Size (Theoretical)	cm <sup>3</sup>
Injection Weight (PS)	g
Injection Rate	g/s
Injection Pressure	Mpa
Plasticizing Capacity(ps)	g/s
Screw Speed	rpm
CLAMPING UNIT	
Clamp Tonnage	KN
Toggle Stroke	mm
Space Between Tie Bars	mm
Max.Mold Height	mm
Min. Mold Height	mm
Ejector Stroke	mm
Ejector Tonnage	KN
OTHERS	
Max. Pump Pressure	Mpa
Pump Motor Power	Kw
Heater Power	Kw
Machine Dimension(LxWxH)	m
Machine Weight	t
Hopper Capacity	Kg
Oil Tank Capacity	L

	MA 860/260G			MA 1200/370G			MA 1600/540G			MA 2000/770G		
	A	B	C	A	B	C	A	B	C	A	B	C
Screw Diameter	32	36	40	36	40	45	40	45	50	45	50	55
Screw L/D Ratio	22.5	20	18	23.3	21	18.7	22.5	20	18	22.2	20	18.2
Shot Size (Theoretical)	121	153	188	173	214	270	253	320	395	366	452	546
Injection Weight (PS)	110	139	171	157	195	246	230	291	359	333	411	497
Injection Rate	77	98	121	89	110	140	110	140	172	141	174	210
Injection Pressure	219	173	140	210	171	135	214	169	137	210	170	141
Plasticizing Capacity(ps)	9.9	11.3	13.9	11.3	13.9	18	13.9	18	21.6	18	21.6	26.6
Screw Speed		0~230			0~195			0~195			0~175	
Clamp Tonnage		860			1200			1600			2000	
Toggle Stroke		310			350			420			470	
Space Between Tie Bars		360X360			410X410			455X455			510X510	
Max.Mold Height		360			430			500			510	
Min. Mold Height		150			150			180			200	
Ejector Stroke		100			120			140			130	
Ejector Tonnage		33			33			33			62	
Max. Pump Pressure		16			16			16			16	
Pump Motor Power		11			13			15			18.5	
Heater Power		7.6			11.55			11.55			16.95	
Machine Dimension(LxWxH)		4.24X1.19X1.88			4.82X1.26X1.97			5.17X1.33X2.05			5.48X1.43X2.15	
Machine Weight		3			4.1			4.9			6.3	
Hopper Capacity		25			25			25			50	
Oil Tank Capacity		170			220			235			310	

Platen dimensions  
Moving platen

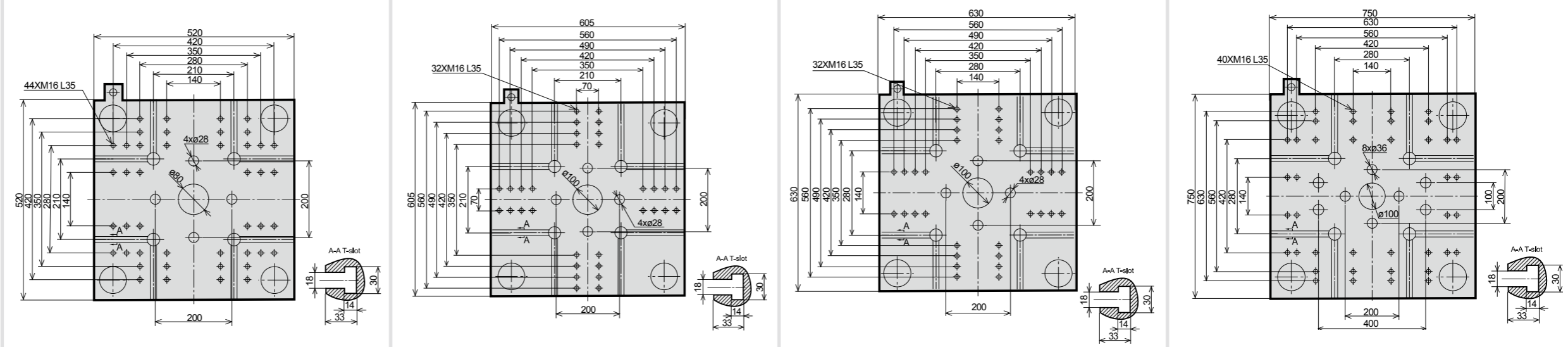

Platen dimensions  
Mounting hole for robot/spure picker top view from fixed platen

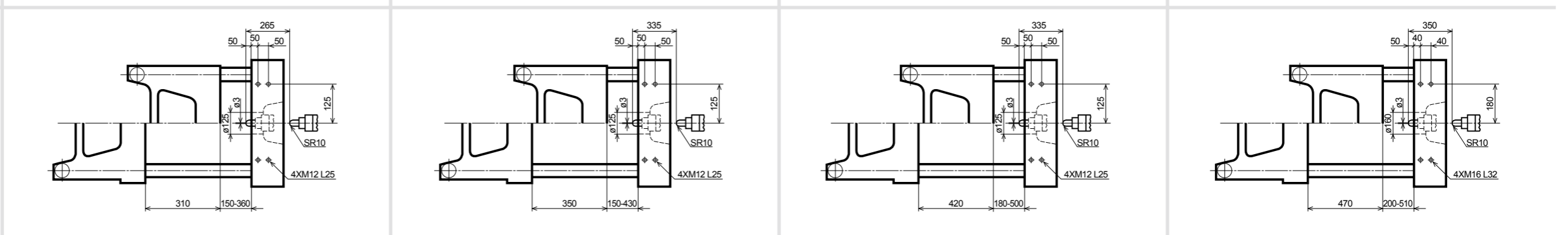

Machine dimensions  
We reserve the right to make changes as a result of furhter technical advantages.

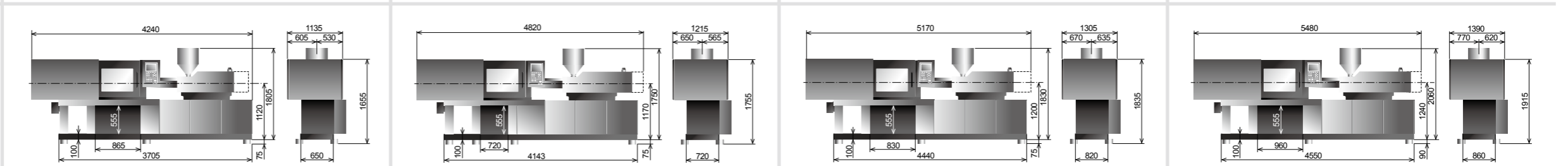

# Specification

INJECTION UNIT	
Screw Diameter	mm
Screw L/D Ratio	L/D
Shot Size (Theoretical)	cm <sup>3</sup>
Injection Weight (PS)	g
Injection Rate	g/s
Injection Pressure	Mpa
Plasticizing Capacity(ps)	g/s
Screw Speed	rpm
CLAMPING UNIT	
Clamp Tonnage	KN
Toggle Stroke	mm
Space Between Tie Bars	mm
Max.Mold Height	mm
Min. Mold Height	mm
Ejector Stroke	mm
Ejector Tonnage	KN
OTHERS	
Max. Pump Pressure	Mpa
Pump Motor Power	Kw
Heater Power	Kw
Machine Dimension(LxWxH)	m
Machine Weight	t
Hopper Capacity	Kg
Oil Tank Capacity	L

	MA 2500/1000G			MA 3000/1800G			MA 3600/2250G			MA 4500/2900G		
	A	B	C	A	B	C	A	B	C	A	B	C
Screw Diameter	50	55	60	60	65	70	65	70	80	70	80	90
Screw L/D Ratio	22	20	18.3	21.7	20	18.6	21.5	20	17.5	22.9	20	17.8
Shot Size (Theoretical)	497	601	715	845	992	1151	1068	1239	1619	1424	1860	2355
Injection Weight (PS)	452	547	651	769	903	1047	972	1127	1473	1296	1693	2143
Injection Rate	173	210	250	238	279	324	279	323	422	366	478	604
Injection Pressure	205	169	142	213	182	157	208	180	138	204	156	123
Plasticizing Capacity(ps)	21.6	26.6	30.3	33.7	38.2	44.9	38.2	44.9	58.7	44.9	58.7	71.8
Screw Speed		0~170			0~190			0~185			0~170	
Clamp Tonnage		2500			3000			3600			4500	
Toggle Stroke		540			600			660			740	
Space Between Tie Bars		570X570			660X660			710X710			780X780	
Max.Mold Height		570			660			710			780	
Min. Mold Height		220			250			250			330	
Ejector Stroke		150			160			160			200	
Ejector Tonnage		62			62			110			110	
Max. Pump Pressure		16			16			16			16	
Pump Motor Power		22			30			37			45	
Heater Power		17.75			24.05			30.65			37.65	
Machine Dimension(LxWxH)		6.16X1.52X2.2			6.88X1.88X2.52			7.5X1.88X2.6			8.1X2.05X2.7	
Machine Weight		7.8			11.3			14.7			18.8	
Hopper Capacity		50			50			50			50	
Oil Tank Capacity		355			550			640			820	

Platen dimensions  
Moving platen

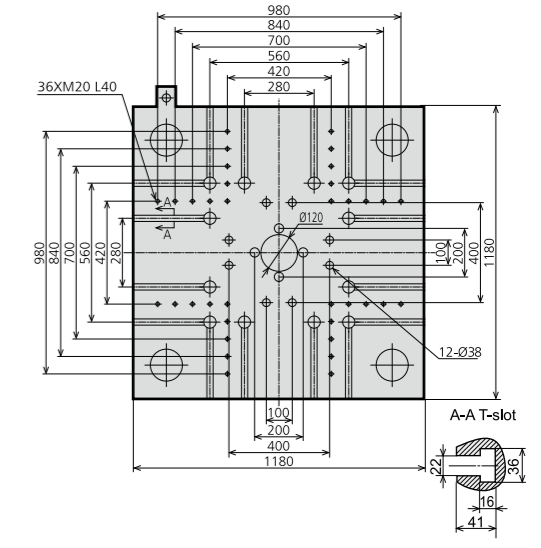
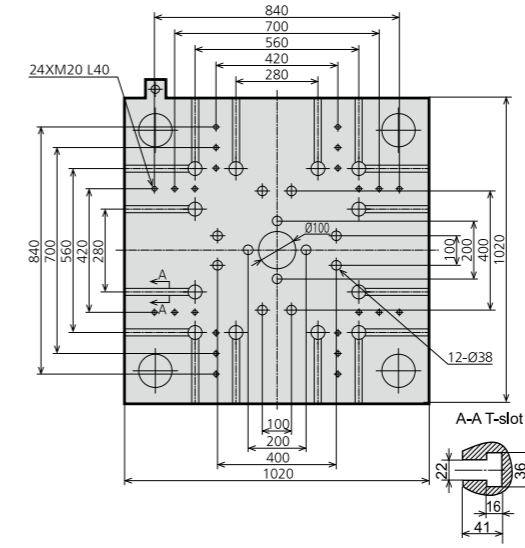
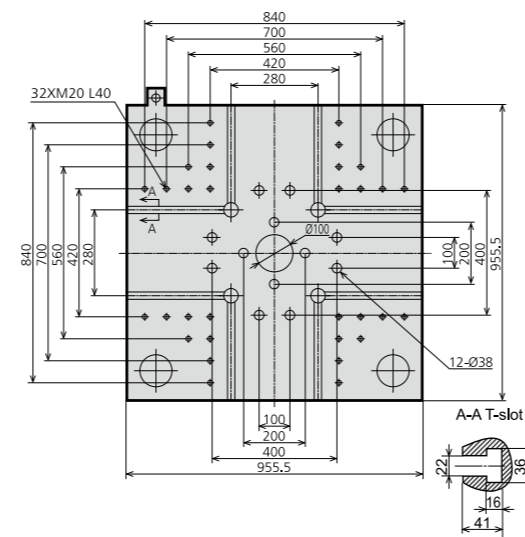
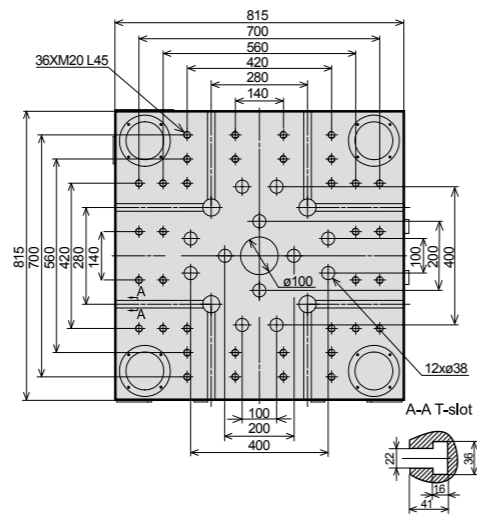

Platen dimensions  
Mounting hole for robot/spure picker top view from fixed platen

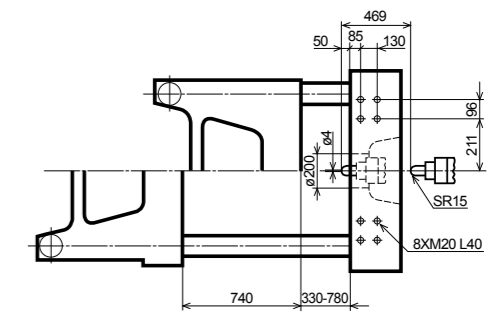
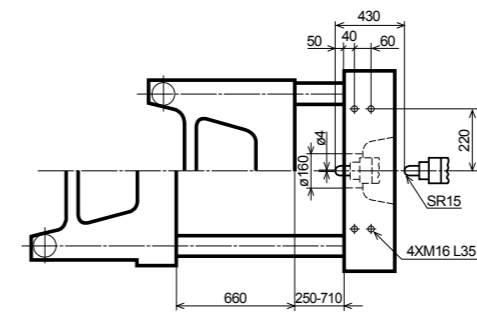
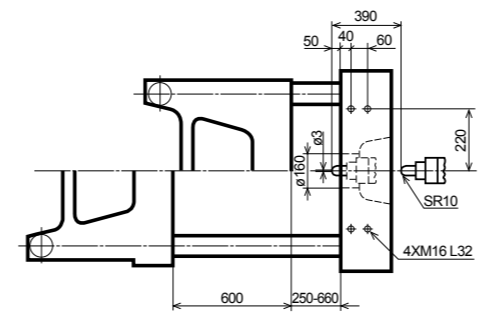
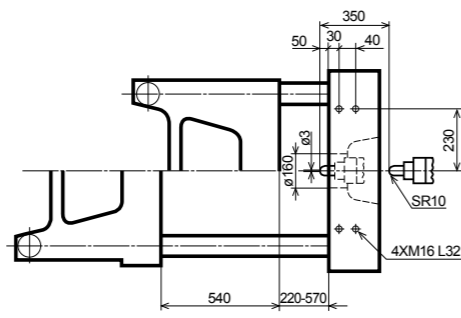

Machine dimensions  
We reserve the right to make changes as a result of further technical advantages.

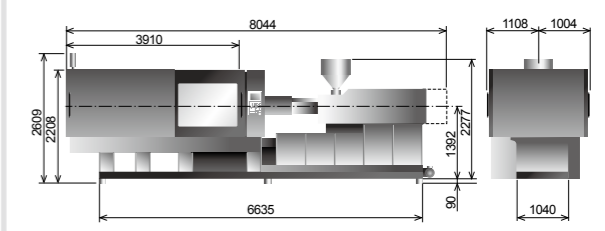
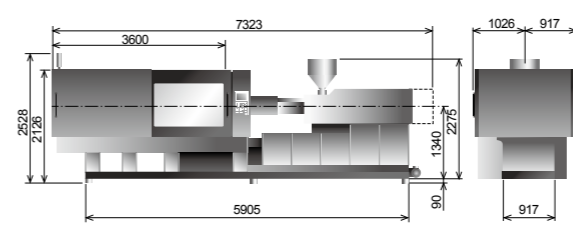
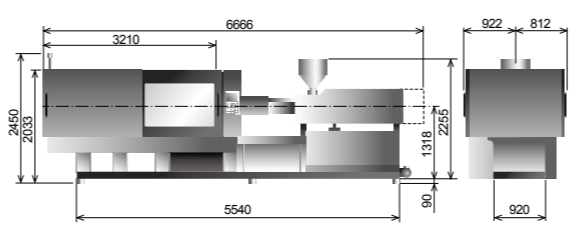
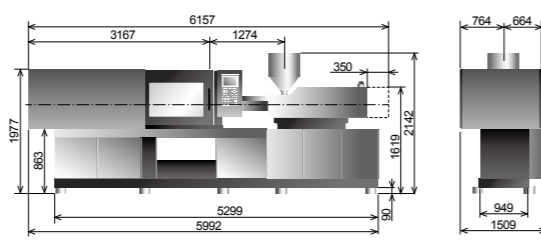

# Specification

INJECTION UNIT	
Screw Diameter	mm
Screw L /D Ratio	L/D
Shot Size (Theoretical)	cm <sup>3</sup>
Injection Weight (PS)	g
Injection Rate	g/s
Injection Pressure	Mpa
Plasticizing Capacity(ps)	g/s
Screw Speed	rpm
CLAMPING UNIT	
Clamp Tonnage	KN
Toggle Stroke	mm
Space Between Tie Bars	mm
Max.Mold Height	mm
Min. Mold Height	mm
Ejector Stroke	mm
Ejector Tonnage	KN
OTHERS	
Max. Pump Pressure	Mpa
Pump Motor Power	Kw
Heater Power	Kw
Machine Dimension(LxWxH)	m
Machine Weight	t
Hopper Capacity	Kg
Oil Tank Capacity	L

	MA 5300/4000G				MA 6500/4550G				MA 7800/6350G				MA 10000/7950G			
	A	B	C	D	A	B	C	D	A	B	C	D	A	B	C	D
Screw Diameter	80	85	90	100	80	90	100	110	90	100	110	120	100	110	120	130
Screw L /D Ratio	22	20.7	19.6	17.6	24.8	22	19.8	18	24.4	22	20	18.3	24.2	22	20.2	18.6
Shot Size (Theoretical)	2212	2497	2799	3456	2036	2576	3181	3849	2799	3456	4181	4976	3770	4562	5429	6371
Injection Weight (PS)	2012	2272	2547	3145	1853	2344	2895	3503	2547	3145	3805	4528	3431	4151	4950	5798
Injection Rate	490	553	620	766	490	620	765	927	543	671	811	966	703	850	1012	1188
Injection Pressure	180	159	142	115	224	177	143	118	228	184	152	128	211	174	146	125
Plasticizing Capacity(ps)	58.7	65.4	71.8	86.5	58.7	71.8	86.5	104	71.8	86.5	104	122	86.5	104	122	139
Screw Speed	0~140				0~140				0~113				0~113			
Clamp Tonnage	5300				6500				7800				10000			
Toggle Stroke	825				900				980				1100			
Space Between Tie Bars	830X800				895X895				980X980				1090X1090			
Max.Mold Height	850				900				980				1100			
Min. Mold Height	350				400				400				500			
Ejector Stroke	200				260				260				320			
Ejector Tonnage	158				186				186				215			
Max. Pump Pressure	16				16				16				16			
Pump Motor Power	55				22+45				22+55				37+55			
Heater Power	45.65				54.25				67.8				81			
Machine Dimension(LxWxH)	9.6X2.3X2.62				10.1X2.32X2.7				10.9X2.42X2.73				11.9X2.68X2.81			
Machine Weight	25				30.2				36				47.5			
Hopper Capacity	100				100				100				100			
Oil Tank Capacity	990				1300				1360				1610			

Platen dimensions  
Moving platen

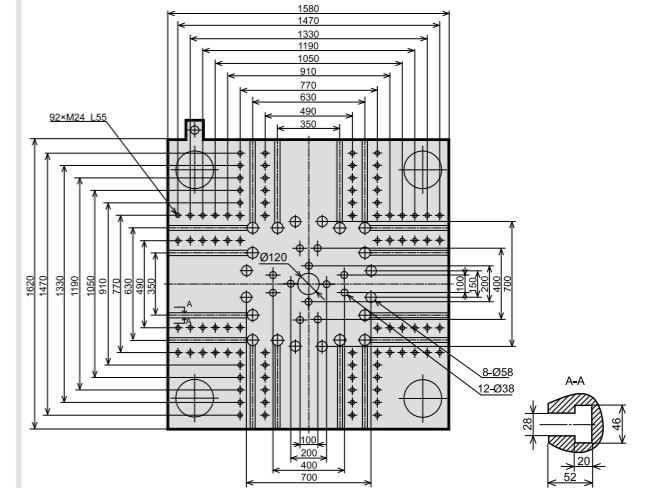
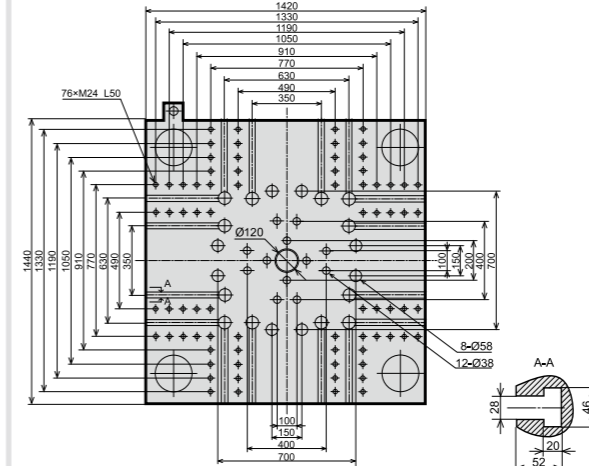
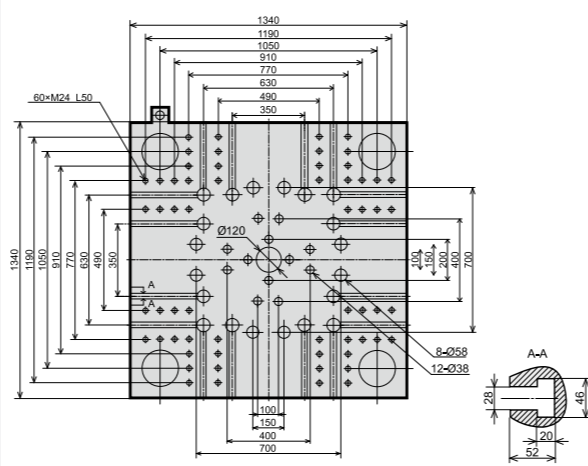
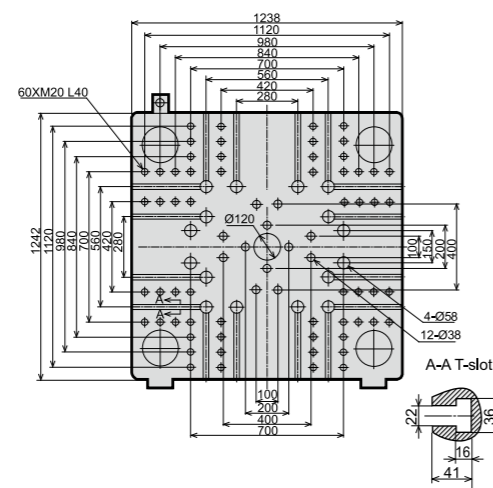

Platen dimensions  
Mounting hole for robot/spure picker top view from fixed platen

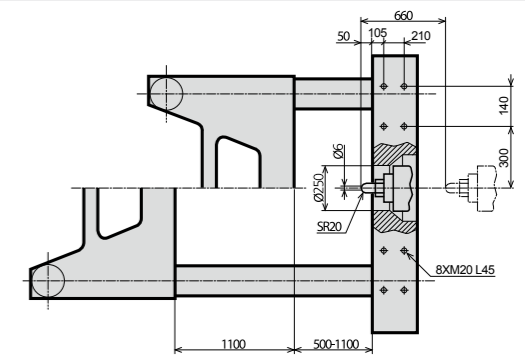
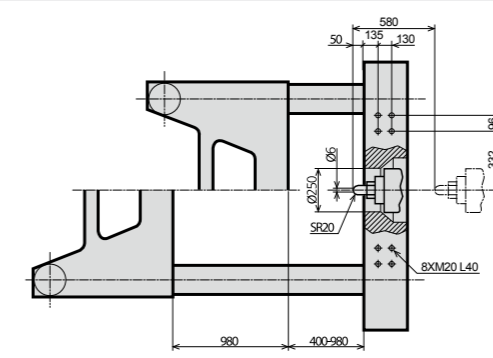
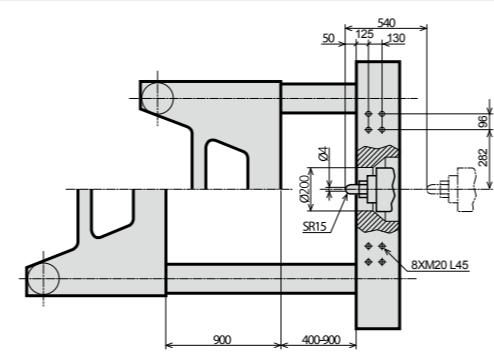
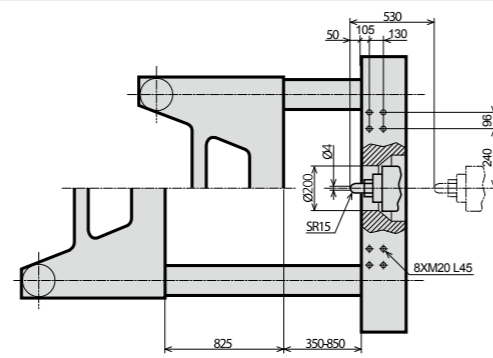

Machine dimensions  
We reserve the right to make changes as a result of furhter technical advantages.

